

## BEVERAGE APPLICATION PUMPS

Refresh your business with Grundfos







## GRUNDFOS AND THE BEVERAGE INDUSTRY

The full-line Grundfos range gives you better peace of mind and optimal pump application compatibility for every stage in your production process.

### 150 years of service

Grundfos is the world's largest pump manufacturer with pump ranges covering every end of the industrial spectrum and the beverage industry is no exception. We are certainly not strangers to beverage production; our expertise and heritage in this quality-driven industry go back 150 years through our Hilge subsidiary.

### Quality products need quality pumps

Our pumps are installed in breweries and soft drink, juice and distillery factories around the world. Grundfos pumps are ideal for this kind of work because they are designed specifically to maintain product integrity and consistency as well as being CIP and SIP compatible. And then there's peace of mind: Grundfos pumps are synonymous with reliability and are backed by a global network complete with service partners in more than 50 countries. With Grundfos pumps you really can ensure your product lives up to your standards – batch after batch.

### The sign of top industrial quality

The characteristic stainless steel Grundfos Industrial Solutions sign symbolises our commitment to industrial professionals. Our pump ranges cover it all: cleaning, dosing, water treatment, water supply, wastewater, cooling, boiler feeding, heating, fire protection and general or sanitary processing. Grundfos Industrial Solutions is determined to become your preferred pump supplier. Read on and let us convince you.

### Breweries

Our sanitary pumps' unique, hygienic design prevents contamination of the beer and ensures the product's characteristics are maintained.

### Juice production

Our wide range caters to the highly varying needs of juice manufacturers, maintaining ingredient integrity and the desired viscosity.

### Distilleries

Here the emphasis is on safe handling in hazardous environments. Naturally, we have the ATEX certification so vital to this industry.

### Soft drinks

Our Cleaning in Place (CIP) and Sterilisation in Place (SIP) capable pumps are ideal for the intricate mixing and carbonising processes in this industry. Residue is reliably cleaned away in time for the next batch.

### Wineries

This venerable tradition requires a high degree of environment control with rigid hygiene standards: contamination is unthinkable. Grundfos sanitary pumps ensure the finished product lives up to its label.





# FULL-LINE SUPPLIER HAS EVERY NEED COVERED

Grundfos is a full-line supplier of pumps for plant service systems and processes. We produce pumps for every facility in the industrial water circuit: delivering water to the plant, moving the water inside the plant to where it's

needed, e.g. for boiler feeding or cooling systems, and finally leading the wastewater out of the plant to a treatment facility.

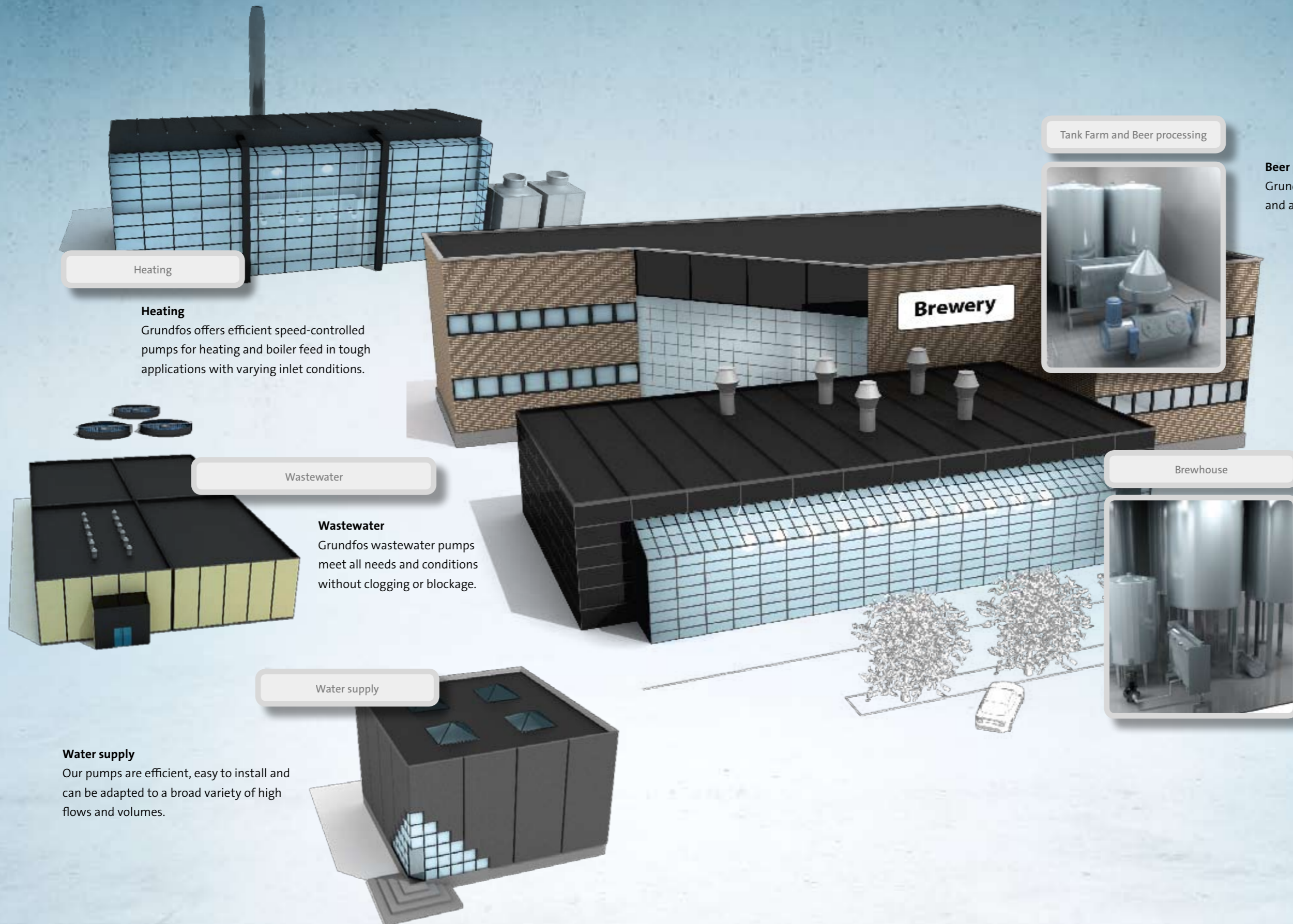

Heating

**Heating**  
Grundfos offers efficient speed-controlled pumps for heating and boiler feed in tough applications with varying inlet conditions.

Wastewater

**Wastewater**  
Grundfos wastewater pumps meet all needs and conditions without clogging or blockage.

Water supply

**Water supply**  
Our pumps are efficient, easy to install and can be adapted to a broad variety of high flows and volumes.

Tank Farm and Beer processing



**Beer processing/tank farm**  
Grundfos products are designed for easy CIP and are extremely robust and reliable.

Brewhouse



**Brewhouse**  
Our MAXA pump can handle cavitation, solids and high temperatures.



# QUALITY PRODUCTS NEED QUALITY PUMPS

In such a diverse and competitive industry you need pumps that contribute to the quality of your product. Grundfos sanitary pumps do, simply because they treat your product better. And this is why:

## HiGenix™

HiGenix™ is the design philosophy behind Grundfos sanitary pumps. It encapsulates the unique manufacturing techniques and dedication to quality that make Grundfos pumps the most hygienic and competitive options available for beverage applications.

## QUALITY MATERIALS

### Cold-rolled stainless steel for reliability

Ordinary pumps are often made of cast stainless steel, with uneven surfaces that cause corrosion and reduced productivity. That's why most Grundfos sanitary pumps are made of cold-rolled stainless steel that provides a robust, homogenous and pore-free surface.

### Polished performance

The surface is electro-polished – which means a completely smooth surface down to the molecular level.

## UNIQUE HYGIENIC DESIGN

Total circulation means no dead ends. The pump casing design and the set position of the input and output connections generate a vortex inside the pump, so the fluid keeps moving.

### Gap-free seal areas

The HiGenix™ design philosophy means Grundfos sanitary pumps are free of edges, seams, screw heads and dead-ends where bacteria particles can accumulate.

### Hygienic shaft seal solutions

In ordinary pumps, the seal is positioned in a seal chamber, generating bacteria-friendly dead-ends. The hygienic shaft seal solutions in Grundfos pumps are mounted in an optimum position in the product flow to ensure lubrication, cooling and CIP and SIP capability.

### Casing drain at the lowest point

All Grundfos sanitary pumps can be equipped with a casing drain at the lowest point, enabling quick, complete drainage of the pump. Grundfos vertical pumps are 100% fully drainable.

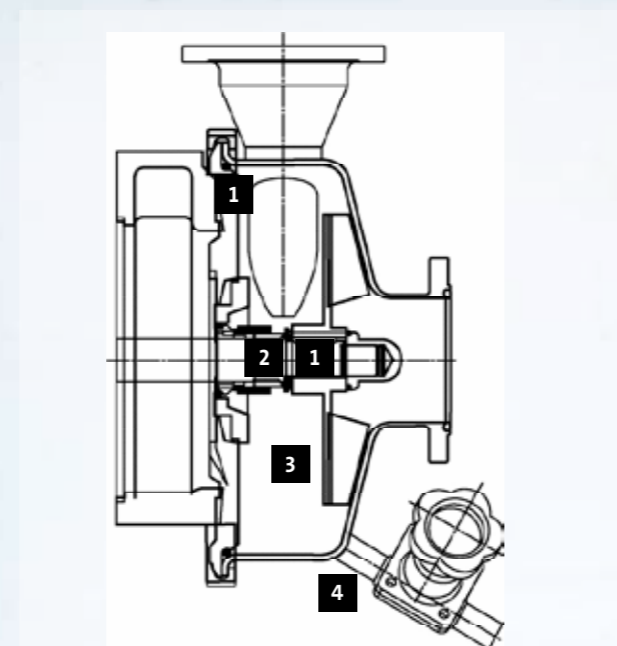
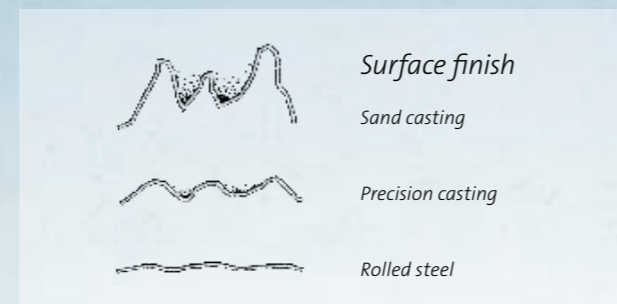

- 1 GAP-FREE SEAL AREAS**  
Rounded corners and edges.  
No gaps, embossing or socket head screws.
- 2 SHAFT SEAL**  
Mounted to ensure optimum lubrication, cooling, CIP/SIP capability.
- 3 DEAD-END FREE PUMP CASING**
- 4 CASING DRAIN AT LOWEST POINT**  
Vertical installation is fully drainable

## CUSTOMISATION

### Customised to fit

With Grundfos, you always get a perfect match to your needs. In a Grundfos Euro-HYGIA®, for instance, you have a choice of connections, impellers, shaft seals, coupling methods, frequency converters, surface finishes, foundations, motors and horizontal and vertical mounting. And that's just for one pump model.

### Certifications

- A** European Hygienic Engineering Design Group
- B** Sanitary Standards
- C** Qualified Hygienic Design



# KEEP THE FLOW GOING WITH GRUNDFOS

Grundfos is a full-line supplier of premium pump solutions. Our range has a variety of models suited to different stages in industrial processes. We can outfit your entire application

with general processes pumps capable of handling your product with care and precision, dosing solutions and sanitary pumps that fulfil the strictest hygienic criteria.

## SANITARY PUMPS

### CIP

All Grundfos sanitary pumps are CIP compatible. Rinsing water and detergent solutions are circulated through tanks, pipes and process lines without dismantling the equipment.



SIPLA

### Highly viscous liquid

Grundfos pumps move syrups, yeast and other similar ingredients gently and safely through the production process.



NOVAlobe

### Large flow applications

As well as hot and cold water transportation, Grundfos pumps can be installed for all types of large flow liquid transfers such as brewing and cross-flow filtration.



MAXA

### Pasteurisation

Grundfos pumps ensure correct pressure and flow.



Contra

### Liquid transfer

Juice and soft drink applications require the flexibility and hygienic design of Grundfos pumps.



F&B HYGIA®

## UTILITY PUMPS

### Water treatment

Grundfos has developed a flexible range of stainless steel pumps and systems that don't contaminate pure water. Naturally, all pressure requirements can be met.



NB/NK

### Water supply

Our range covers both pressure tank systems and frequency-controlled systems. It includes submersible SP pumps for bore hole applications, as well as in-line and end-suction pumps for backwash applications, and DMS/DME dosing pumps for water chlorination.



Hydro Booster system

### Wastewater

Solids and other particles in wastewater cause wear requiring robust pumps. Our range varies from small stainless steel drainage pumps to large wastewater pumps with up to 600 kW motor power.



SE

### Cooling & Heating

The Grundfos pump range includes numerous pump types for cooling and heating applications, water-borne as well as various other media. Solutions for high-temperature applications are also available. All pumps can be supplied with speed-regulated motors which offer major advantages in terms of dimensioning and energy savings.



TP

### Boiler feeding

Grundfos has customised a CR pump version with low NPSH, specially designed for systems with poor inlet conditions. This improves the NPSH-value outside the pump's normal duty range. We recommend speed-regulated pumps (E-pumps) for boiler feed. CRN/BM pumps are ideal for water replenishment.



CRE

## DOSING & DISINFECTION

### Dosing

You can make a DME pump run at full capacity simply by pressing the 100% key. This means that the pump is fully primed for the next cycle. And with a turndown ratio of 1-1000, DME pumps are accurate down to the smallest dose.



DME

### Disinfection

Easily installable Grundfos Oxiperm Pro systems produce chlorine dioxide using diluted solutions of sodium chlorite (NaClO<sub>2</sub> 7.5%) and hydrochloric acid (HCl 9%). All maintenance is performed at the front of the unit, minimising disruption.



Oxiperm PRO



## A FULL RANGE OF PUMPS FOR AUTOMATED HYGIENE

A challenge in food and beverage processes is to achieve both impeccable cleaning and disinfecting results and maintain tight cost control. The industry response to this challenge is threefold: integrate components that work most efficiently together, link the components up to central monitoring and control units, and finally, automate.

Jürgen Löhke GmbH specialises in just that. With their innovative clean-in-place technology (CIP) Löhke has developed a niche in the food processing industry, particularly in brewing, beverages and dairy. Automation plays a central role in meeting both the quality and cost-efficiency objectives.

“We call it automated hygiene,” explains commercial managing director, Martin Löhke.

### The situation

Löhke’s unique CIP concept requires pumps that deliver the highest standards of quality and longevity. In order to automate the CIP process, there must be a communication capability to facilitate monitoring and controlling of the system components.

Löhke needed a pump solution that could dose chemicals as efficiently as possible into the CIP processes. This would enable Löhke to meet their stringent environmental and cost requirements for saving significant amounts of water and cleaning chemicals. They chose Grundfos.

### The Grundfos solution

The good news for Löhke is that they can get all the various pumps they need from one source: Grundfos.

- Precise DDI dosing pumps to dispense the cleaning agent
- Single-stage EHEDG-certified hygiene pumps for CIP circulation
- CRN pressure boosters for open-plant cleaning equipment

A notable characteristic of DDI pumps is the incredibly simple ‘What you set is what you get’ operation with no complicated calculations. A two-button interface is all that is needed to set the numerical value for the required dosage.

### The outcome

Löhke highlights the complete logical solutions, problem-free interfaces and better component synergies as being the benefits from sourcing all its pumps from Grundfos. Martin Löhke: “Grundfos is the optimal solution for us. We can buy all of our pumps from one source,” This guarantees a leaner procurement process as well as more economical planning and development. “Furthermore, we value the service that is available worldwide thanks to the global infrastructure of the Grundfos Group.”



## PRESERVING TRADITIONS AT JACOBSEN’S BREWHOUSE

### Old-fashioned beers are back!

The kettles at Husbryggeriet Jacobsen (Jacobsen’s Brewhouse), located in Copenhagen’s historic Carlsberg headquarters, are brewing specialty beers as never before. In recent years the beer market has gone full circle, with consumers increasingly demanding beer that reflects old-fashioned tastes and traditions.

Accordingly, in June 2005 Carlsberg opened Jacobsen’s Brewhouse – a microbrewery dedicated to faithfully recreating the beer recipes of 1897, the year the old Carlsberg brewery was established.

### Delicate processes need quality equipment

The production processes behind traditional beers call for special care – as well as flexible, high-quality hygienic production equipment.

The fermentation process is critical. Several beer labels are brewed on the same production line. High-grade sanitary pumps help prevent cross-contamination during the fermentation processes ensuring that each beer label tastes exactly as it should.

A CIP (Clean in Place) solution outfitted with Grundfos pumps thoroughly cleans the system after each batch to maintain homogeneous quality and taste.

### When standards must be upheld

Grundfos sanitary pumps are designed to provide no breeding grounds for bacteria and germs. The designs comply with the industry’s strictest hygienic requirements, a must for the complex fermentation processes at Jacobsen’s Brewhouse. All Grundfos sanitary pumps are backed by the appropriate certification and comply with formalised market standards.

### A happy master brewer

Today the full range of Grundfos high-grade stainless steel sanitary pumps are represented at Jacobsen’s Brewhouse. Master brewer Jens Magnus Eiken says: “A good sanitary pump is a pump that adds excellence to the brewing process – and it is a pump that you don’t even notice is there! Only the best sanitary pumps on the market are good enough for our processes, and the Grundfos range helps us ensure a high-quality production of specialty beers.”

## GRUNDFOS INDUSTRIAL SOLUTIONS

The full-line Grundfos range caters to the specific needs of wineries, breweries, distilleries and juice producers. Grundfos sanitary pumps give you better peace of mind and application compatibility during every stage of your production process. Our range has models specifically designed to handle viscous, delicate or temperature-sensitive ingredients – all with maximum care and hygiene.

At Grundfos we know reliability and easy maintenance are critical factors in keeping the production flow going. That is why our sanitary pumps can be customised for optimal performance. And, most importantly, all Grundfos pumps come with the expertise and global support network of the Grundfos Group.

**Grundfos A/S**  
Poul Due Jensens Vej 7  
DK-8850 Bjerringbro  
Denmark  
Phone: (+45) 8750 1400

[www.grundfos.com/industry](http://www.grundfos.com/industry)